

Manual Make-up/refill unit for refill operations with pressurised and non-pressurised seal flushing systems.

FLO-PAC® type HMS

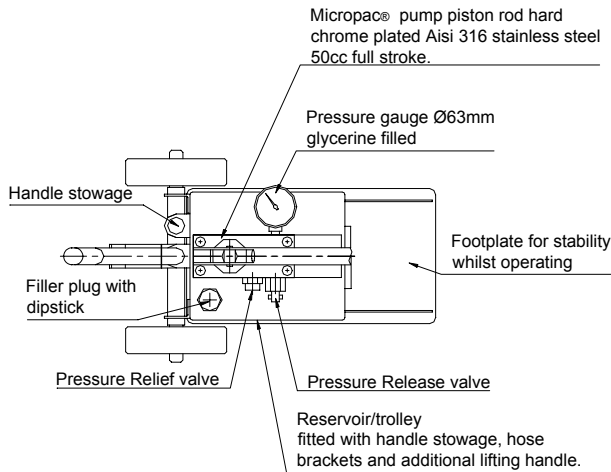

Standard configuration:

- A high quality Micropac® robust and compact hand pump, with a stroke capacity of 50cc per full stroke.
- A hard chrome plated stainless steel piston rod for durable operation.
- A mobile liquid reservoir, in volumes 5, 10, 20 or 50 Ltr.^(*)
- Any pressure capability up to 100 bar (std.= 40 bar).
- Complete with safety relief valve.
- Complete with pressure release valve.
- Complete with poppet check valve.
- Complete with suction strainer.
- Complete with glycerine filled pressure indicator.
- Complete with filler/breather and dipstick.
- Complete with 2.5mtr. pressure hose and quick coupling. (other hoses/ connections upon request)
- Nitrile O-rings and PTFE piston and bearing seals.

Reservoir volume:

- Model HMS-5- : 5 Ltr.^(*)
- Model HMS-10- : 10 Ltr.^(*)
- Model HMS-20- : 20 Ltr.^(*)
- Model HMS-50- : 50 Ltr.^(*)

Material configuration:

- W : Anodised alloy for mineral oils and water
- SW : Stainless steel /bronze for mineral oils, water and most other liquids.

Settings/range (specify if different from standard):

- Pressure indicator : 0-..... bar(g). (Std. 0-40 bar)
- Safety relief valve : bar(g). (Std. setting 40 bar)

Optional:

- Unit can be fitted with an air driven pump for ease of operation. Manual pump remains as back-up pump.
- Operating pressures up to 700 bar(g) available on request.
- Reservoir volumes up to 300 Ltrs. available on request.
- other pressure connections (flanges etc.) available on request.
- Soft parts in EPDM or Viton available on request.

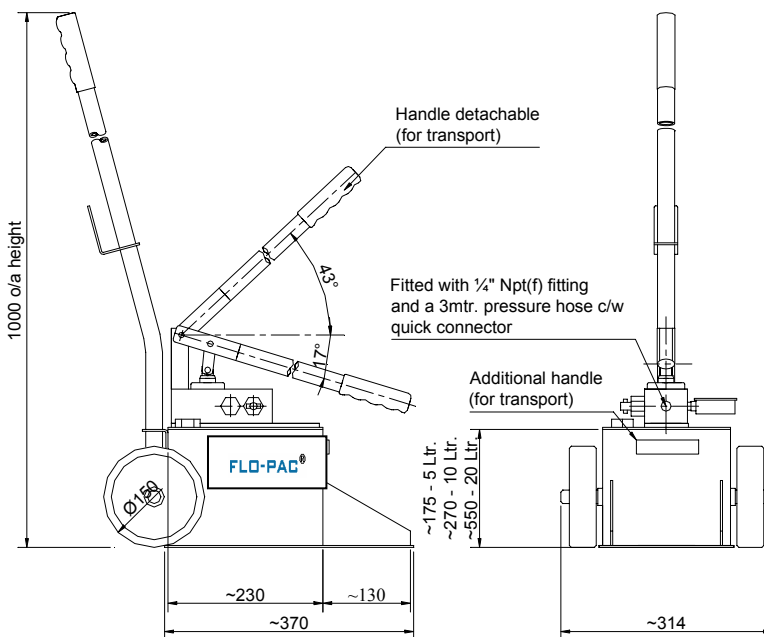

All soft parts are easily replaceable to guarantee a long service life.

HPS also has available special engineered static make-up units, (the HDS series) using pneumatic or electrical drivers as desired. Units can be job specific engineered to clients requirements. Please consult our applications department.

Ordering code: Flo-Pac® - HMS + Reservoir volume + Material configuration code + Safety valve setting in bar.

Example : **Flo-Pac® HMS – 20 – SW – 40**
Specifies : a Flo-Pac HMS unit with 20 Ltr. reservoir, in stainless steel with a MAWP of 40 bar = setting of the safety relief valve

^(*) Suitable for approx. 2 systems in one run.
⁽²⁾ Suitable for approx. 4 systems in one run.
⁽³⁾ Suitable for approx. 8 systems in one run.
⁽⁴⁾ Suitable for approx. 20 systems in one run ; 50ltr size is in view of weight not recommended unless applied in clean areas with flat and hardened floors.